

Hire Boat

Safe Operations Manual



Polycraft 4.1m with 40HP Tiller 2 Stroke Engine.

ID. 453436

Class 4D Leisure Craft of <5m

Operational Area - Partially Smooth Waters

Cardwell to Forrest Beach, QLD

The Trustee of I'MON Family Trust Wild Hinchinbrook Adventures ABN 11 640 039 027

Referred to herein as 'Wild Hinchinbrook Adventures'

Owner / Operator:

Mr Benjamin Weston, 302a Mount Gardiner Rd, Qld. 4850.

Email: wildhinchinbrook@icloud.com

Operation Summary

The business contains an office/base station in 302a Mount Gardiner Road, Qld, 4850

Vessel operations are in partially smooth waters within designated limits of 2 nautical miles from the coastline between Forrest Beach and Cardwell, North Queensland (as pictured on page 7).

Boats are hired out on a hire and drive basis.

Vessel Information

Vessel type: Polycraft Drifter 4.1m with 40HP 4 stroke petrol engine.

Identifier: 453436

Equipment list:

- 4 personal flotation devices (PFDs).
- One buoyant appliance with light and 30m buoyant line.
- 2 red hand flares and 2 orange smoke flares
- 1kg (ABE powder) extinguisher
- Manual bilge pump
- "V" Sheet
- 1 Waterproof torch
- First aid kit
- Anchor and rope
- Chart covering the operating area. Digital & Laminated area chart
- Safe Operation Manual
- Garmin Chartplotter
- Set of paddles
- 1 x mooring ropes
- 1 x manual bailer (bucket)
- 1 x compass, whistle and reflective device (mirror)
- Laminated Safety Handbook
- Burke throw bag

Wild Hinchinbrook Adventures welcomes you aboard and wish you the *Ultimate Hinchinbrook Experience*.

Your safety is paramount, and the Hirer's Safety Operation Manual serves to:

- Familiarise clients with the boat and its various safety features;
and
- Provide important information to the nominated skipper to assist him or her to operate the boat safely and in accordance with the Hire Agreement.

Limits of the Hire operating Area

For the purpose of this Hirer's Safe Operation Manual, the operating area and geographical boundaries/limits of operation are defined in the chart on page 7 of this manual. A laminated copy of the chart provided on each boat.

It is the nominated skipper's responsibility to ensure the operation of the hire boat is at all times confined to the waters that fall within the boundaries/limits of operation. If uncertain of the Hire boat's position relative to these limits of operation, make immediate contact with the base station to seek further clarification.

Safety Briefing

A safety briefing to hirers prior to vessel handover is mandatory. This briefing covers all matters listed on the hire agreement.

Hours of Operation

Hire boats only to be navigated between sunrise and sunset, with daylight visibility. The nominated skipper is responsible for ensuring the boat is moored at a specified safe anchorage outside these times, or trailered.

Safe Anchorages

Safe anchorage locations are areas within the operating area boundaries that are deemed suitable by the nominated skipper with consideration of weather conditions.

Communications

The hirer or nominated skipper agrees to carry a charged mobile phone. A hand held VHF radio will be supplied if the hirer does not have a suitable means of communication in an emergency.

Consumption of Alcohol

Nominated skippers and persons in charge of a vessel at any time while underway must comply with must comply with State law regarding blood alcohol levels. (i.e – less than .05%)

Nominated Skipper Competency Nomination

Nominated skipper/s must hold a current recreational boat license and satisfactorily complete the competency assessment.

Emergency Response

A response protocol to report an emergency situation is outlined on pages 8 to 11.

Emergency Communication Protocol

In the case where a handheld VHF radio has been supplied, and a mobile phone is not able to be used: A hand held VHF radio is provided for communications between the vessels and the coast guard in emergencies. The radio is located in the forward storage locker and instructions on how to operate the radio were given in the safety brief, and outlined on pages 12 and 13.

The nominated skipper must as soon as practicable to immediately Hinchinbrook Hire Boats by mobile, or Coast Guard VHF radio Ch 16 in the event of any of the following situations:

- Any emergency situation as defined under the Emergency Plans section of this manual; and
- Any other incident, accident or circumstance that presents a threat to the safety of the vessel or those aboard.

The nominated skipper may use the VHF radio to liaise directly with emergency response agencies in accordance with the Emergency Plans section of this manual. The use of the radio in this way is confined to the following situations:

- The nature of the emergency warrants immediate communication with emergency response agencies to ensure the safety and well-being of those aboard.
- If circumstances allow it, Hinchinbrook Hire Boats is also contacted on 0429870999 or 0408012767 to alert the business to the situation.

Vessel Safety Equipment

Location:

The physical location of the safety equipment is addressed with hirer during the safety briefing. The information is also detailed within this booklet.

The nominated skipper and other persons aboard are to familiarise themselves with this information and the correct use/application of the safety equipment.

Lifejackets

The Hire boat accommodates up to 4 persons and is equipped with 4 personal flotation devices (PFDs). These are located in nominated storage compartments indicated with signage.

The lifejacket donning instructions can be found on each lifejacket.

Rescue Throw Bag

The Hire boat is equipped with a rescue throw bag with a light & 30m of buoyant rope. This equipment is only to be used in emergency situations to assist with the recovery of a person from the water.

Flares

The Hire boat is equipped with 2 red hand flares and 2 orange smoke flares, which are stored in the watertight bag in the forward storage compartment.

Portable Fire Extinguisher

The hire boat is fitted with the following portable fire extinguisher:

- A 1kg (ABE powder) extinguisher is located in the forward storage compartment of the vessel.

Bilge Pump

The Hire boat is fitted with 1 manual electric bilge pump. The pump provides for the evacuation of water from the bilge. The safety briefing will cover how to operate the bilge pump.

V Sheet & Waterproof Torch

A V Sheet and 1 waterproof torch are provided and they are located with the flares in the bag located in the forward storage locker.

First Aid Kit

A first aid kit is located in the waterproof bag in the front storage locker. The use of the first aid kit is confined to the treatment of minor cuts, burns, abrasions. Any injury or illness of a more serious nature is to be immediately reported in accordance with the medical emergency plan detailed in this manual.

Compass

The Hire boat has a flush mounted compass, which can be used for navigation in an emergency. This is located of the fire wall of the casting deck.

Navigation Lights

Navigation lights fitted to the vessel and turned on via switch panel. A battery operated Anchor light is located in the front storage locker.

Other Miscellaneous Equipment

The hire boat is also fitted with the following equipment:

- Anchor and cable
- Electronic and laminated chart covering the Hire boat operating area
- GPS & Depth sounder
- 1x Mooring line

Main Propulsion Machinery

The Hire boats are fitted with a 2 Stroke petrol engine. They are serviced and maintained in accordance with the manufacturer's recommendations. The main engine has been checked and tested prior to your departure.

An engine SOP is on page 13 for reference. It contains instructions for the start-up and shut down of the main engine. In the event that an engine failure occurs or a visual/audible alarm is activated at the console the nominated skipper is to contact Wild Hinchinbrook Adventures in the first instance on 0431195141 or 0480304993. Failing that, Seek assistance from nearby vessels, or Coast Guard via VHF radio on channel 22/16.

Routine Monitoring of the Engine & Reporting Faults

The nominated skipper should regularly monitor alarms, lights, and irregular noises and vibrations during engine operation. The skipper also should check if a water tell tail is present. Should an alarm activate at any time during the course of the Hire the nominated skipper is to:

- Immediately contact the base station using mobile to inform of the situation.
- Follow all instructions received from the base station.

Garbage/Refuse

No garbage or refuse is to be discharged overboard. It must be disposed of in bins supplied at the boat ramps or at Hinchinbrook Hire Boats base on completion of the Hire.

Pets

Pets are allowed on board the boat during the hire. The nominated skipper and owners of pet/s aboard are responsible for the safety and welfare of pet/s onboard including in an emergency situation.

A lifejacket for pets is **not provided**.

Cleaning

Please ensure you remove your personal belongings. You do not need to give the boat a full wash or run/flush the engine, however, this would be appreciated for multiday hires.

Fuel

All vessels are to be returned refueled to a full tank. However, this can be done by Wild Hinchinbrook Adventures at a fixed rate of \$3/litre which can be deducted from your bond. Walk on walk off customers are not required to refuel, however, they need to ensure enough fuel is left in the tank to get the boat to the boat ramp.

Operational Limits Chart

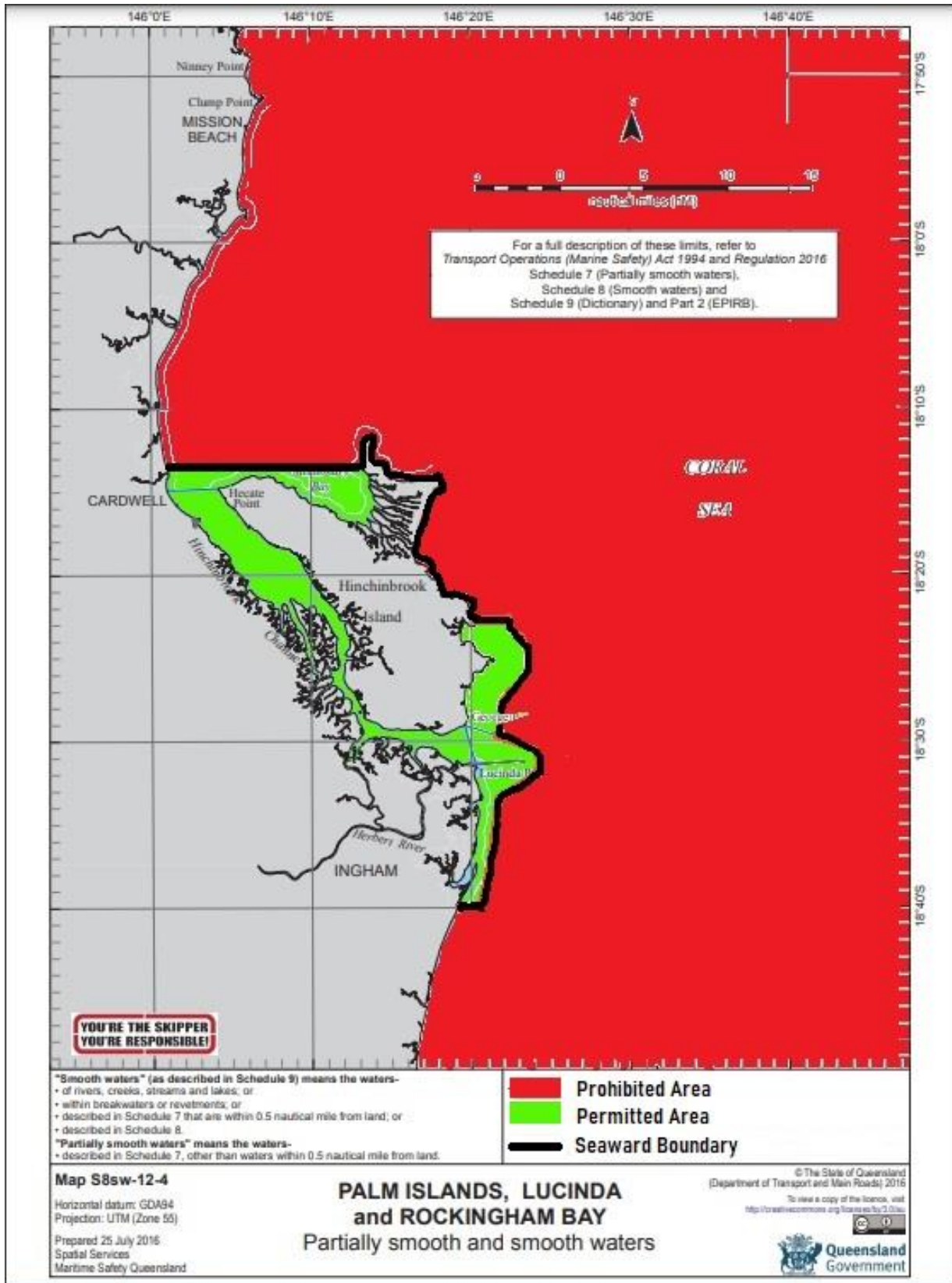

Wild Hinchinbrook Adventures - Emergency Plans

Person Overboard

Persons on Board:

- Raise alarm **SHOUT “MAN OVERBOARD”**
- If vessel is under power, immediately put engine in neutral
- Maintain visual contact with the person in the water
- Slowly maneuver vessel to provide for recovery of person in the water and stop main engine
- Secure the lifebuoy line to a strong point on the vessel and throw lifebuoy to person in the water
- Assist person back aboard via the side or back of the boat
- Call emergency services for painful or life threatening injuries.
- Call Hinchinbrook Hire Boats to assist where possible.
- Render first aid as necessary
- Initiate medical emergency plan if necessary

Person in the water:

- Raise alarm **SHOUT “MAN OVERBOARD”** and continue to do so
- If you're wearing a lifejacket – use whistle on lifejacket to attract attention
- Stay calm and relaxed
- Do not board the vessel if the main engine is operating

Fire in the Boat or Engine

- Raise alarm **SHOUT “FIRE, FIRE. FIRE”**
- Stop main engine
- Quickly assess situation, if safe to do so use the fire bucket or portable fire extinguisher to extinguish
- Nominated skipper to instruct passengers to locate their lifejackets & don
- Render first aid if required
- Prepare to evacuate vessel if fire cannot be contained
- Call emergency services for painful or life threatening injuries.
- Call Hinchinbrook Hire Boats to assist where possible.
- Use VHF radio to issue a mayday and abandon vessel

Collision

- If vessel is under power, immediately put engine in neutral
- Check for injuries or damage
- If safe to do so, take measures to control any flooding
- Render first aid to any persons injured

- If another vessel is involved render assistance if able to do so
- If flooding cannot be controlled have passengers don their lifejackets
- Stay with the vessel. It is designed to float if flooded.
- Call emergency services for painful or life threatening injuries.
- Call Hinchinbrook Hire Boats to assist where possible.
- Use VHF radio to issue mayday and abandon the vessel if required

Grounding

- Check for injuries or damage
- If safe to do so take measures to control any flooding
- Render first aid to any persons injured
- If possible and safe to do so take vessel to the nearest specified safe anchorage or alternate safe haven
- If flooding cannot be controlled have passengers don their lifejackets
- Call emergency services for painful or life threatening injuries.
- Call Hinchinbrook Hire Boats to assist where possible.
- Proceed to the nearest safe anchorage or safe haven.
- Use the VHF radio to inform the base station of: the situation; your current location; and intentions
- Instruct those aboard to don their life jackets
- Use VHF radio to maintain communications with the base station
- Use VHF radio to issue call for emergency assistance if the need arises
- Render first aid using First Aid Kit as appropriate
- Reassure casualty and keep them calm
- Continually monitor condition of the casualty and use radio to maintain communications with the base station and emergency response agencies

Instructions for Donning a PFD/Lifejacket are clearly marked each PFD, located in the storage locker, signed LIFEJACKETS.

Refueling

A spare 5L orange jerry can of unleaded fuel has been provided for emergency purposes. If you are required to use the 5L please follow the procedures below and **IMMEDIATELY** return to port.

- Remove fuel cap of main fuel tank,
- Remove the lid of the the 5L orange jerry and insert the filler spout into the lid and fix to the jerry can.
- Pour fuel into the fuel tank ensuring minimal spillage.

ENSURE THERE ARE NO OPEN FLAMES NEAR ANY FUEL.

CROCODILES

Crocodiles live in fresh and salt water in northern Queensland. Swim only in designated safe swimming areas. (Not many around here.) Even if there is no warning sign, there may still be crocodiles.

Safety tips when in crocodile-inhabited areas:

- obey all crocodile warning signs always keep a watch for crocodiles
- never provoke, harass or interfere with crocodiles, even small ones
- never feed crocodiles. It is illegal and dangerous
- be extra careful around water at night and during the breeding season (September–April)
- stay away from the water's edge.
- Don't hang over the side of the vessel or have arms or legs dangling outside the vessel.
- Don't slap the water to encourage their curiosity.
- Don't discard fish scraps near populated places such as boat ramps.
- Camp a long way from the water's edge.

MARINE STINGERS

Queensland is home to several species of dangerous tropical marine stingers, including the box jellyfish and the Irukandji. Marine stingers are present in tropical Queensland waters all year round but the risk is higher during the marine stinger season (November–May).

Sting treatment:

If stung, dial Triple Zero 000 and ask for an ambulance. While waiting for the ambulance, pour vinegar onto the sting and administer oxygen or CPR if required. Symptoms of Irukandji stings may take 20–40 minutes to develop—if in doubt, seek medical aid.

Sending a Distress Call via VHF Radio

You may only have a very short time to send a distress call. Here is the procedure in this order:

1. Tune your VHF to channel 16.
2. Repeat the word "MAYDAY," three times.
3. "This is Wild Hinchinbrook Adventures Hire Poly" Repeat boat name three times.
4. Describe your boat, such as, size, rig type, color and tell the number of persons aboard. "white, 4m vessel, x passengers onboard"
5. Indicate the nature of distress (sinking, fire, etc.)
6. Give position by latitude and longitude or by bearing and distance to a well-known landmark or navigational aid, or in any terms that will assist a responding station in locating the vessel in distress. Include any information, such as, vessel course, speed, and destination. Indicate the kind of assistance desired.
7. End with "over."

If you do not receive any answer, repeat your call every 2 minutes.

Note: If you are NOT in a life-threatening situation but still are in real need of assistance, use the same procedure as above, EXCEPT that in step 2, you replace the word MAYDAY by the the words "Pan Pan" (pronounce PAHNN PAHNN)., and only if you are unable to get telephone contact with Hinchinbrook Hire Boats. Tel 0429870999 or 0408012767 first.

GME VHF Marine Radio

Key Functions

Key	Short Press	Long Press (> 3 sec)
Hi/LO /Lock	TX Power Hi/Low	Key Lock
16	CH 16	User Programmable Priority Channel
DW/TRIW	Dual Watch mode	Triple Watch mode
Power Switch	On	Off
SCAN	All Scan/All Memory Scan	Priority all/memory Scan
MEM	MEMORY Mode	Save/Delete Memory Channel
Up/Down	Channel Up/Down	Channel Fast Up/Down
CH/WX/UIC	Channel/Weather	Band Selection
VOL/SQL	VOLUME Set	SQUELCH Set

KEY ARRANGEMENT

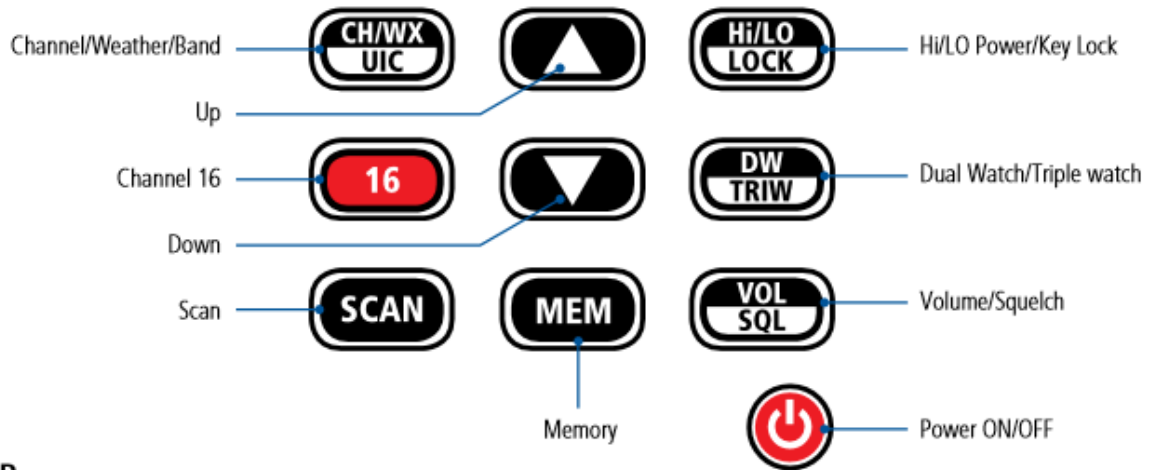

LCD

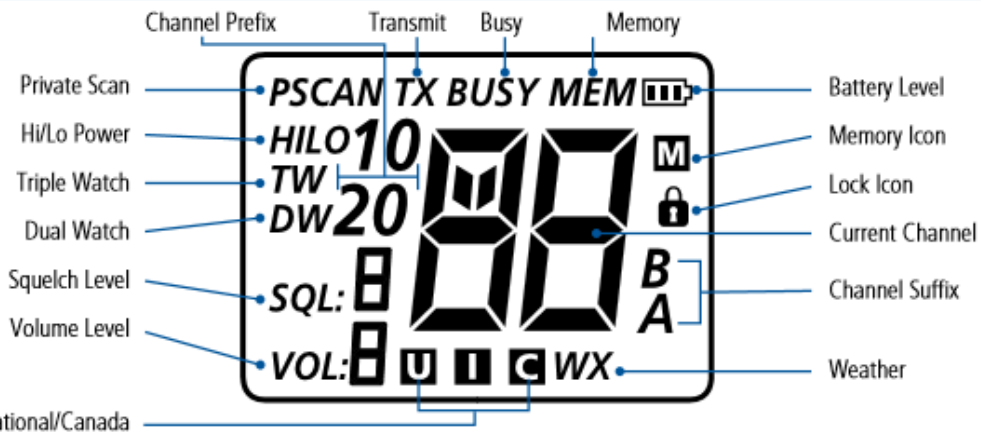

Outboard Engine SOP

Starting engine:

- Ensure boat is in the water
- Tilt engine down noting depth for propeller to clear the bottom
- Straighten engine
- Gear must be in neutral, or engine will not start.
- Place safety outboard kill switch lanyard over the wrist you'll be using to operate the tiller.
- Turn the key on the tiller handle, until the engine

Turning off the engine:

- Place gear in neutral
- Watch depth for the propeller in the water. (Hitting rocks/boat ramp etc)
- Turn key off
- Tilt engine up.

Note: Ensure the breather valve on top of the fuel tank cap is released. Failure to release the valve could cause engine to stall.

Restricted Fishing Zones

GRMPA zones are highlighted on the Innisfail GBRMPA maps in yellow in green. The green zones are No Fishing zones, and are outside of the operational limits of your vessel. Yellow zones are restricted fishing zones, and you will need to confirm with the zoning map or website the restrictions in place.

Green zones will also be visible on the map on the Garmin Chart plotter.

Safe Navigation of the Hinchinbrook Channel and Creeks

